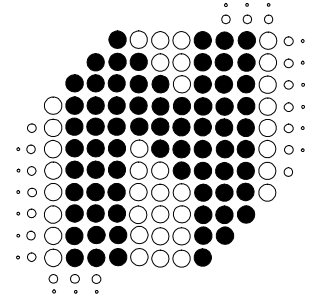

NORTECH

Nortech International (Pty) Ltd
PO Box 4099
Willowton Hub
Pietermaritzburg
3200 South Africa

32A Wiganthorpe Road
Pietermaritzburg
3201 South Africa
Reg. No. 98/1095

Tel: (033) 345 3456
Fax: (033) 394 6449
E-mail: mkt@nortech.co.za

Int. Tel: +27 33 345 3456
Int Fax: +27 33 394 6449
URL: www.nortech.co.za



PD230 Enhanced Vehicle Detector USER MANUAL

NORTECH INTERNATIONAL (PTY) LTD

All rights reserved.

Copyright © 2009

Document No.: 302UM0017_01

Date of issue: July 2010

This document is for information only and unless otherwise indicated it is not to form part of any contract. In accordance with the manufacturer's policy of continually updating and improving design, specifications contained herein are subject to alterations without notice.

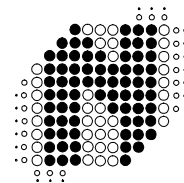
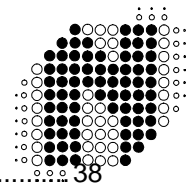

Table of Contents

1. INTRODUCTION.....	5
2. TECHNICAL DATA	7
2.1 Functional Data	7
2.2 Electrical Data	7
2.3 Environmental Data.....	8
2.4 Mechanical Data.....	9
2.5 Approvals	9
3. OPERATING INSTRUCTIONS.....	10
3.1 Hardware Set-up.....	10
3.2 Switch Setting Selections.....	10
3.2.1 Frequency Switch.....	10
3.2.2 Sensitivity	10
3.2.3 Automatic Sensitivity Boost	11
3.2.4 Presence Time	11
3.2.5 Pulse / Presence	11
3.2.6 Reset Switch.....	11
3.3 Internal Link Selection.....	13
3.4 Power Fail (Option)	13
3.5 Front Panel Indicators	13
4. PRINCIPLE OF OPERATION	15
4.1 Detector Tuning.....	15
4.2 Detector Sensitivity.....	15
4.3 Modes of Operation.....	16
4.3.1 Presence Mode	16
4.3.2 Pulse Mode.....	16
4.3.3 AB Logic Presence Mode (Barrier Operation).....	17
4.3.4 AB Logic Pulse Mode (Counting Logic).....	20
4.4 Response Times	23
5. INSTALLATION GUIDE	25
5.1 Product Safety Requirements	25
5.2 Operational Constraints.....	25
5.2.1 Environmental Factors to Consider	25
5.2.2 Crosstalk.....	26
5.2.3 Reinforcing	26
5.3 Loop and Feeder Material Specification.....	26
5.4 Sensing Loop Geometry.....	27
5.5 Loop Installation	27
6. CONFIGURATION.....	30
6.1 PD231 Enhanced Detector : English.....	30
6.2 PD232 Enhanced Detector: English.....	31
6.3 PD234 Enhanced Detector: English.....	31
7. APPLICATIONS	32
8. CUSTOMER FAULT ANALYSIS.....	33
8.1 Fault Finding.....	33
8.2 DU100 – Detector Diagnostic Unit	34
8.2.1 Interpretation of the DU 100 readings	34
8.2.1.1 Frequency.....	34
8.3 Functional Test.....	36
APPENDIX A - FCC ADVISORY STATEMENT	37
APPENDIX B – INSTALLATION OUTDOORS	38
Appendix B.1 IEC 60950-22:2005 – Outdoor cabinet.....	38



Appendix B.2 IEC 60950-22:2005 - Northern Europe..... 38

Appendix B.3 IEC 60950-1:2005 – Overvoltage Category..... 38

APPENDIX C - REQUEST FOR TECHNICAL SUPPORT FORM..... 39

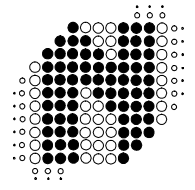

WARNING: 1. THIS UNIT MUST BE EARTHED !

WARNING: 2. DISCONNECT POWER BEFORE WORKING ON THIS UNIT !

WARNING: 3. INSTALLATION AND OPERATION BY SERVICE PERSONNEL ONLY !

WARNING: 4. NO USER SERVICEABLE PARTS INSIDE. ONLY SERVICE PERSONNEL MAY OPEN THE UNIT TO CHANGE INTERNAL SETTINGS!

WARNING: 5. Always suspend traffic through the barrier area during installation and testing that may result in unexpected operation of the barrier

WARNING: 6. USA

FCC Advisory Statement – Refer to Appendix A at the end of this document.

WARNING: 7. Europe

Disposing of the product.

This electronic product is subject to the EU Directive 2002/96/EC for Waste Electrical and Electronic Equipment (WEEE). As such, this product must not be disposed of at a local municipal waste collection point. Please refer to local regulations for directions on how to dispose of this product in an environmental friendly manner.



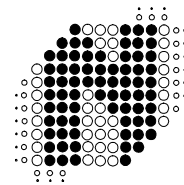

1. INTRODUCTION

The “**PD230 Enhanced Two Channel Inductive Loop Vehicle Detector**” is a dual channel microprocessor based detector designed specifically for parking and vehicle access control applications. The PD230 Enhanced detector has been designed using the latest technology in order to meet the requirements of a vast number of parking applications in terms of operating conditions. A number of internal functional options are available to the user.

The primary function of the detector is to detect vehicle presence by means of an inductance change caused by the vehicle passing over a wire loop buried under the road surface.



The detector has been designed around the popular PD130 series of single channel detectors for ease of installation and convenience. The various modes are selected by changing the position of switches on the front of the unit.

The detector oscillator is multiplexed to eliminate any possibility of crosstalk between the loops connected to the detector.

The switches allow for different loop frequency settings, sensitivity settings and mode settings.

The unit has a number of internally selectable options for configuration of the relay outputs.

The PD230 Enhanced 2 Channel Vehicle Detector provides visual outputs (LED) on the front of the enclosure and relay change-over contacts at the 11 pin connector at the rear of the enclosure. The power LED indicates that the unit has been powered. The channel status LED's below indicate that a vehicle is present over the loop and when there is a fault on the loop. The Presence relays are normally fail-safe and will close on a vehicle detect, loop failure or in the event of a power failure.

Available is an additional Power-fail function which enables a short (of up to ten minutes) power-fail, to have no effect on the operation of the detector when power is restored. The detector will revert to the same state as prior to power failure, when power is restored.

For additional information refer to the following documents:

Data Sheet - PD230 Enhanced 2 Ch Vehicle Detector
Installation Leaflet
Diagnostic Unit DU100 User Manual

Document No. 302DS0002
Document No. 879LF0006
Document No. 895UM0001

2/4 Ch Vehicle Detector Installation Guide

Document No. 879LF0006

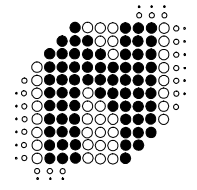

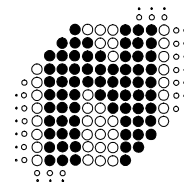

2. TECHNICAL DATA

2.1 Functional Data

Tuning	Fully automatic
Self-tuning range	20 to 1000 μ H
Sensitivity	Four step switch selectable: High 0.02% Δ L/L Medium-High 0.05% Δ L/L Medium-Low 0.10% Δ L/L Low 0.50% Δ L/L
Frequency	Four step selectable: Frequency dependent on loop size
Automatic Sensitivity Boost	Switch selectable
Modes	Output relays may operate in the Presence (fail-safe), Pulse or Direction logic modes
Presence Time	Switch selectable: Limited presence Permanent presence
Pulse Output Duration	150/250 millisecond options
Response Times	100 milliseconds
Drift Compensation Rate	Approx. 1% Δ L/L per minute
Visual Indication	1 x Power LED - Red 2 x Channel Status LEDs - Green
Relay Outputs	2 x Relays, User Configurable as Presence or Pulse outputs, Normally Open (N/O) contacts (Opto-Isolated Outputs are available on request. MOQ applies)
Reset	Reset by push button on front of enclosure
Surge Protection	Loop isolation transformer, gas discharge tubes, and Zener diode clamping on loop input
Power Fail (Option)	10 minutes memory retention of detector state on power failure.

2.2 Electrical Data

Power requirements	120V AC \pm 10% 48 to 62Hz (PD231 models) 230V AC \pm 10% 48 to 62Hz (PD232 models) PD231 and PD232 models: 1.5 VA Maximum at 230V 12V - 10% to 24V + 10% DC/AC 48 to 62Hz (PD234 models)
--------------------	--

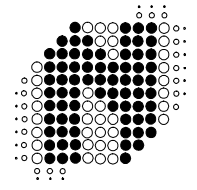

PD234 models: 1 VA Maximum at 12V

Relay Contact Rating

2 x Relays rated - 5A @ 230 VAC

For ambient temperatures above 60 °C De-rate the relay maximum current as per graph below

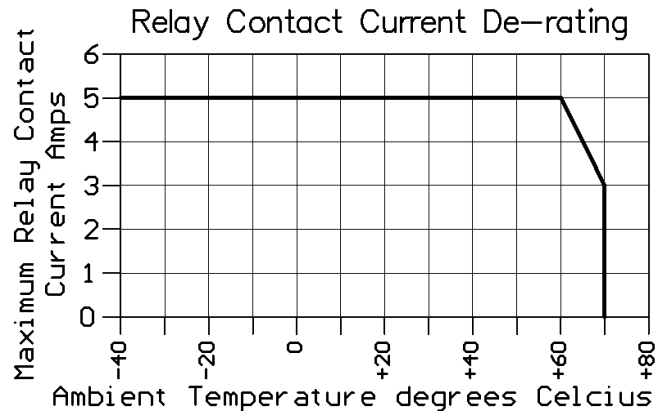

Opto-Isolated Output rating

33 V 50 mA

Note - Opto-Isolated Outputs are available on request. MOQ applies

2.3 Environmental Data

Storage Temperature	-40°C to +85°C
Operating Temperature	-40°C to +70°C
Humidity	Up to 95% relative humidity without condensation
Circuit Protection	Conformal coating over the PCB and all components
IP Rating	IP 30. - This product MUST be installed in an enclosure

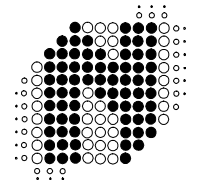

2.4 Mechanical Data

Housing material	ABS blend
Mounting Position	Shelf or DIN rail mounting
Connections	11-pin submagnal type (JEDEC No. B11– 88)
Size of Housing	78mm (High) x 41mm (Wide) x 80mm (Deep)

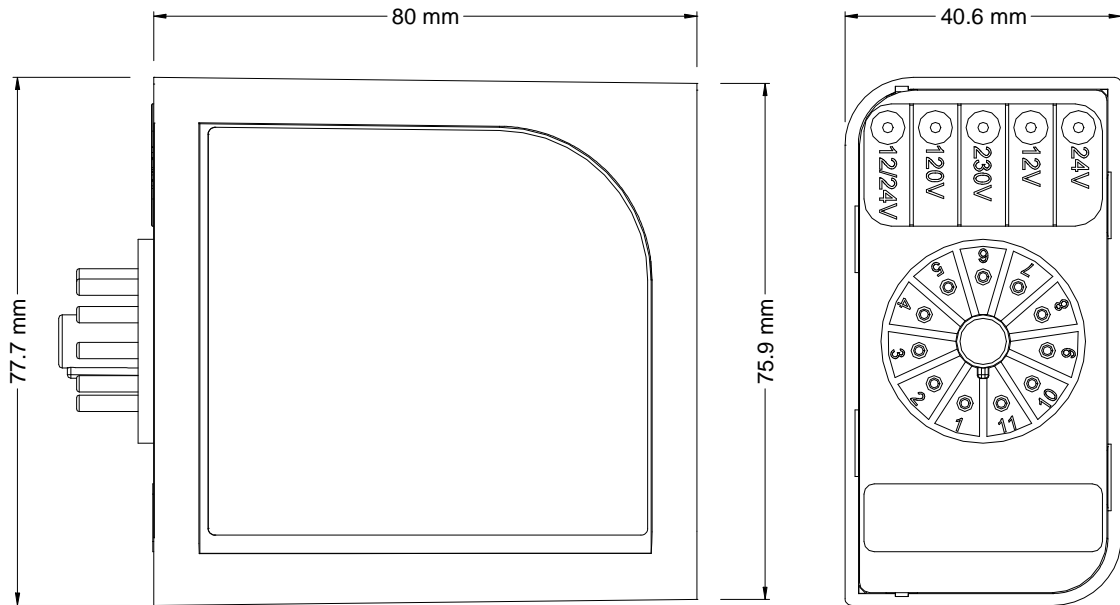

2.5 Approvals

C.E. Regulations	EN 301 489-3	Equipment Type: III Class of Equipment: 2
	EN 50293	Performance Criteria B
Safety:	IEC / EN 60950-1	

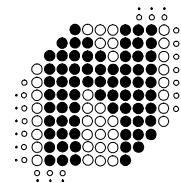

3. OPERATING INSTRUCTIONS

3.1 Hardware Set-up

The PD230 Enhanced dual channel parking detector is designed to be shelf or DIN rail mounted with the controls and visual indicators at the front and wiring at the rear of the enclosure.

The power, loop and relay outputs are all connected to the single 11-pin plug, which is mounted at the rear of the enclosure.

3.2 Switch Setting Selections

3.2.1 Frequency Switch

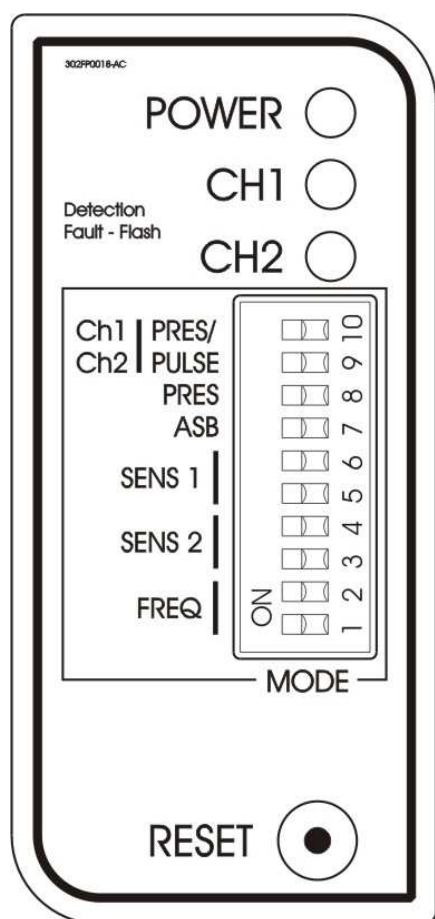

Where more than one detector is used at the same site, the detectors must be set-up to ensure that there is no **CROSSTALK** (interference) between adjacent loops connected to different detectors.

For more information about crosstalk refer to section 5.2.2.

The frequency switches are the lower two switches, numbered 1 and 2. There are four frequency selections and are set as follows:

S1	S2	Frequency Setting
Off	Off	High frequency
Off	On	Medium-High frequency
On	Off	Medium-Low frequency
On	On	Low frequency

The frequency switches allows the operating frequencies of the detector to be shifted higher or lower depending on the switch setting.

The operating frequency of the detector channel is determined by:
 Inductance of the loop and feeder cable
 Detector frequency switch settings

The operating frequency of the detector channel increases as the loop inductance decreases and vice versa.

The inductance of the loop and feeder cable is determined by:
 Size of the loop
 Number of turns in the loop
 Length of feeder cable

As a general rule, the detector connected to the inductive loop with the greatest inductance should be set to operate at the lowest frequency.

When the frequency switch setting is altered, the operating frequency of both detector channels will shift. Because the unit has a common oscillator and the multiplexer connects the loops alternatively to this oscillator.

3.2.2 Sensitivity

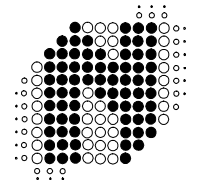

The sensitivity of the detector allows the detector to be selective as to the change of inductance necessary to produce an output. There are four sensitivity selections and are set as follows: -

Channel1		Channel 2		
S6	S5	S4	S3	
Off	Off	Off	Off	High
On	Off	On	Off	Medium-High
Off	On	Off	On	Medium-Low
On	On	On	On	Low

3.2.3 Automatic Sensitivity Boost

Automatic sensitivity boost is a mode which alters the undetect level of the detector. This mode is selected by switch No. 7 on the front of the enclosure and is set as follows: -

S7	
Off	Disabled
On	Enabled

Automatic sensitivity boost causes the sensitivity to be boosted to a maximum on detection of the vehicle, and maintained at this level during the presence of the entire vehicle over the loop. When the vehicle departs the loop and detection is lost the sensitivity reverts to the pre-selected level.

3.2.4 Presence Time

The presence time may be set to permanent presence or to limited presence. In permanent presence mode the detector will continuously compensate for all environmental changes whilst there is a vehicle present over the loop. In limited presence mode there will be a finite time that the detector will remain in detect. This time is dependent on the change of inductance that the vehicle caused. The presence mode is set with switch No. 8 and is set as follows: -

S8	
Off	Limited Presence
On	Permanent Presence

3.2.5 Pulse / Presence

The channel's relay may be set to either **Pulse Mode** or **Presence Mode** with switches No. 9 & No. 10 as shown in the table below: -

Channel1	Channel 2	
S10	S9	
Off	Off	Presence
On	On	Pulse

3.2.6 Reset Switch

The detector automatically tunes to the inductive loops connected to it when power is applied, whether on initial installation or after any break in the power supply. Should it be necessary to retune the detector, as may be required after the changing of any switch selections or after moving the detector from one installation to another, momentary operation of the RESET switch will initiate the automatic tuning cycle.

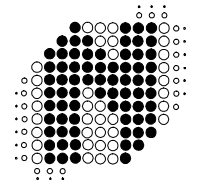

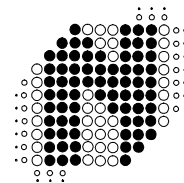

3.3 Internal Link Selection

WARNING - ONLY SERVICE PERSONNEL MAY OPEN THE UNIT TO CHANGE INTERNAL SETTINGS!

There is one 3 way link located inside the PD230 Enhanced detector housing, which is used to alter the mode of operation of the detector. The link has been placed inside the unit to avoid incorrect operation due to selection by an unauthorised operator.

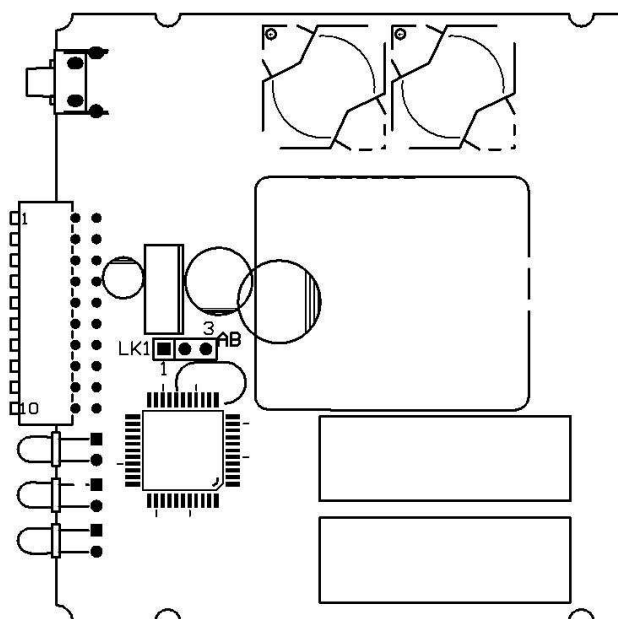

LK1	AB Logic Selection	
	Link from Pin 1 to Pin 2	Presence AB Logic
	Link from Pin 2 to Pin 3	Pulse AB Logic
	Link open Leave link on Pin 2 only	No AB Logic

For a description of the AB Logic mode refer to section 4.3 “Modes of Operation” below

For the PD230 Enhanced parking detector, the default setting for both channel output relays is presence mode (Front panel switches 9 & 10 OFF) with **no AB logic** (i.e. no jumper on LK1).

3.4 Power Fail (Option)

Power-Fail-Option is available on request. MOQ applies

The detector (with Power-Fail Option) is able to retain the output state for a power failure of not greater than 10 minutes. Thus, when the power is restored, the detector will not re-tune but return to the detect state prior to the power failure. If a vehicle was on the loop during power failure, it will remain detected when power is restored.

3.5 Front Panel Indicators

While the detector is tuning, the Channel LED will indicate the “mode” status of the detector.

- i) Any Channel output operating in the presence or pulse modes will come on and extinguish when the system is tuned.
- ii) When the AB Logic mode is selected, the Channel LED's will alternatively flash slow and extinguish when the system is tuned.

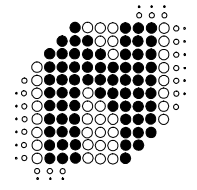

If a loop fault exists the Channel LED will come on and flash indicating a fault. If the fault is self-healing the detector will continue to operate and the LED will continue to show the historical fault. The detector must be reset or power removed to clear the historical fault information.

The channel LED will also glow whenever a vehicle is detected passing over the inductive loop.

The Power LED at the top of the unit will remain on to indicate that the unit is powered. This LED is also used as the link to the diagnostic unit (DU100).

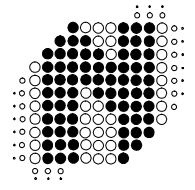

4. PRINCIPLE OF OPERATION

The inductive loop vehicle detector senses the presence of a vehicle over an area defined by a loop of two or more turns of wire laid under the road or pavement surface. This loop of wire is connected to the detector by a pair of wires called a loop feeder.

A vehicle passing over a sensing loop causes a small reduction in the inductance of the loop, which is sensed by the detector. The sensitivity of detection is adjustable to accommodate a wide range of vehicle types as well as different loop and feeder combinations.

Upon detection of a vehicle passing over the loop the detector operates its output relays which may be used to indicate controls associated with the installation.

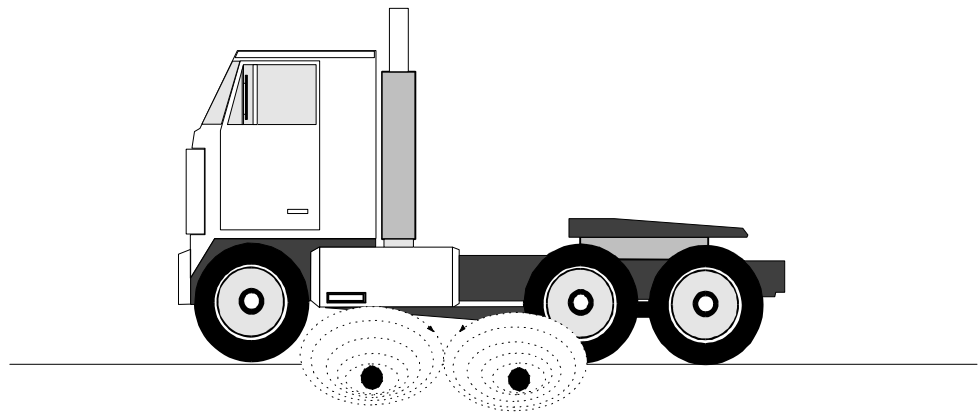

4.1 Detector Tuning

Tuning of the detector is fully automatic. The detector will re-tune if any of the following events occur:-

- When power is applied to the detector.
- A detector reset is initiated via the reset button.
- A detect of greater than 15% $\Delta L/L$ occurs.

The detector will automatically tune each channel to its connected loop. The detector will tune to any loop in the inductance range of 20 to 1000 micro henries.

This wide range ensures that all loop sizes and feeder combinations will be accommodated in the tuning range of the detector.

Once tuned, any slow environmental change in loop inductance is fed to a compensating circuit within the detector, which keeps the detector correctly tuned.

4.2 Detector Sensitivity

Sensitivity of the detection system is dependent on factors such as loop size, number of turns in the loop, feeder length and the presence of metal reinforcing beneath the loop.

The nature of the application determines the required sensitivity, which may be adjusted by means of the front panel controls.

Sensitivity levels on the PD230 Enhanced detector have been carefully optimised for parking and vehicle access control applications. The detection of small, unwanted objects such as bicycles and trolleys can be eliminated by selecting lower sensitivity levels, whilst high-bed vehicles and vehicle/trailer combinations will not lose detection by using the **A**utomatic **S**ensitivity **B**oost (ASB) option.

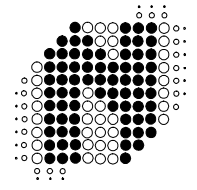

ASB operates as follows. When ASB is disabled the undetect level is dependent on the sensitivity setting of the detector. Hence as the detector is made less sensitive, the undetect level will be reduced accordingly. When the ASB is enabled the undetect level will always be the same irrespective of the sensitivity setting and will be equivalent to the undetect level when the sensitivity is on maximum setting.

4.3 Modes of Operation

The PD230 Enhanced Detector may be configured for any one of the following modes:

- Presence Mode
- Pulse Mode
- AB Logic Presence Mode (Barrier Operation)
- AB Logic Pulse Mode (Counting Logic)

4.3.1 Presence Mode

Link LK1 open

To set Channel 1 to Presence mode switch OFF switch 10

To set Channel 2 to Presence mode switch OFF switch 9

In the presence mode the detector channels operate independently

In the presence mode the detector will give a continuous output during the presence of a vehicle over the inductive loop. As the detector is designed with the permanent presence feature, the detector will indicate vehicle presence for an unlimited period of time.

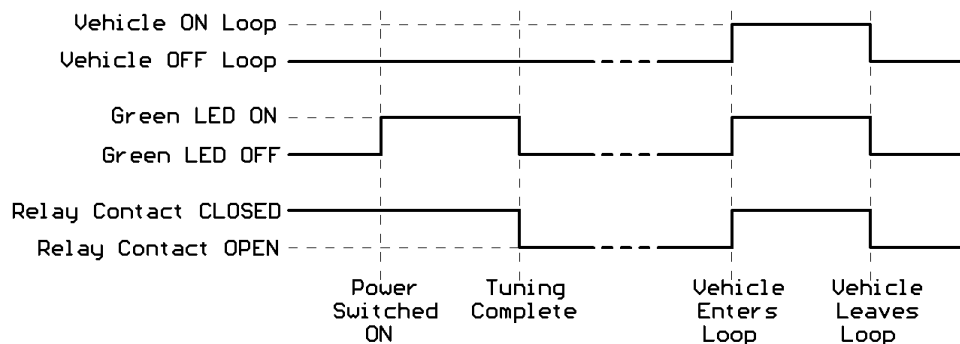

The presence outputs are known as fail-safe outputs. This implies that in the event of a power failure or loop failure the detector will give detect outputs. (Fail-Secure Presence Mode is available on request. MOQ applies)

If permanent presence is not selected, then the detect time will be dependent on the change of inductance. The presence time on the limited presence setting will be approximately 1 hour for an inductance change of 3% Δ L/L.

4.3.2 Pulse Mode

Link LK1 open

To set Channel 1 to Pulse mode switch ON switch 10

To set Channel 2 to Pulse mode switch ON switch 9

In the pulse mode the detector channels operate independently.

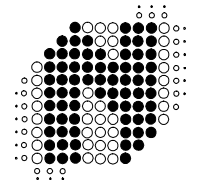

In the pulse mode the detector will give a pulse of 150 millisecond duration, when a vehicle enters the loop (Pulse on Detect) (a pulse of 250 millisecond is available on request. MOQ applies).

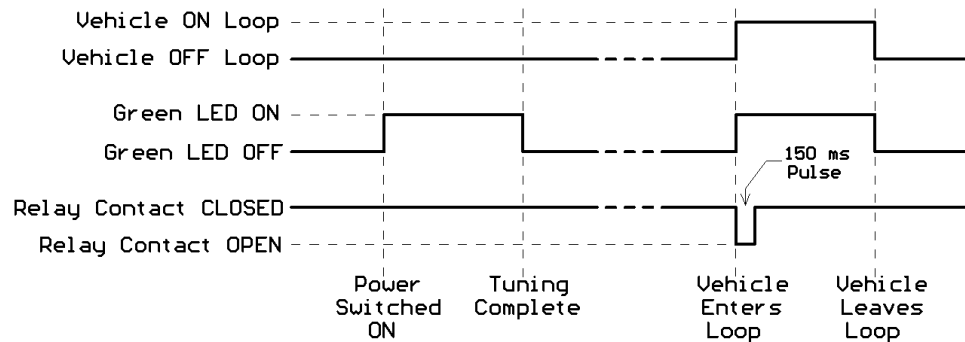

(Pulse on un-detect is available on request. MOQ applies)

4.3.3 AB Logic Presence Mode (Barrier Operation)

Internal link LK1 shorted from Pin 1 to Pin 2. In this mode switches 9 & 10 are ignored.

AB LOGIC Presence Mode is a direction logic mode, and is capable of determining direction of travel of a vehicle. Two loops are laid in the direction of travel to provide the input for this mode.

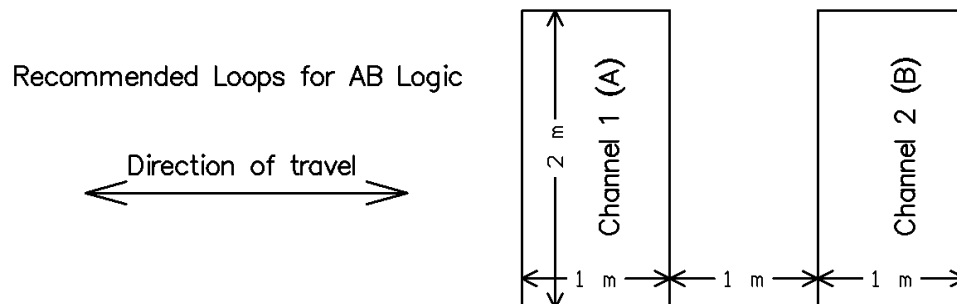

If a vehicle enters Channel 1 Loop and then proceeds to Channel 2 Loop, Channel 1 relay contacts will close for the duration of that the vehicle is over Channel 2 Loop.

If a vehicle enters Channel 2 Loop and then proceeds to Channel 1 Loop, Channel 2 relay contacts will close for the duration of that the vehicle is over Channel 1 Loop.

Progress of a vehicle over the loops

Case 1: (AB LOGIC Presence Mode)

Forward direction

- A - Vehicle Enters Loop1
- B - Vehicle Exits Loop 1,
- C - Vehicle Enters Loop2,
- D - Vehicle Exits Loop 2,

Typically caused by loops being too far apart or very small vehicles

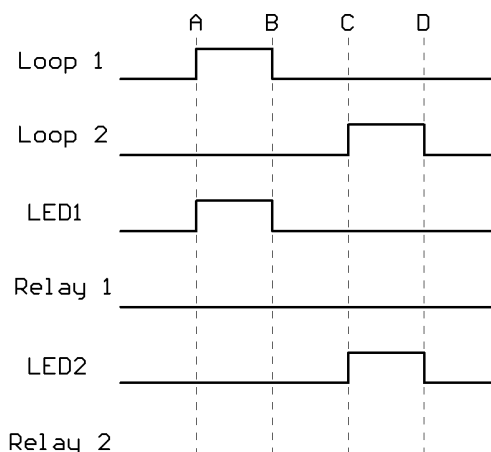

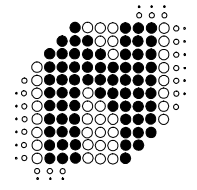

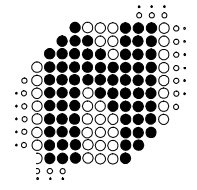

Case 2: (AB LOGIC Presence Mode)

Forward direction

- A - Vehicle Enters Loop1
- B - Vehicle Enters Loop2
- C - Vehicle Exits Loop 1
- D - Vehicle Exits Loop 2

This is the correct forward operation for Presence AB Logic

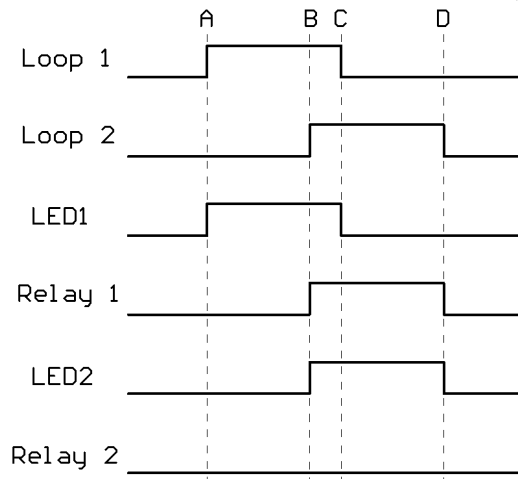

Case 3: (AB LOGIC Presence Mode)

Reverse direction

- A - Vehicle Enters Loop2
- B - Vehicle Exits Loop 2
- C - Vehicle Enters Loop1
- D - Vehicle Exits Loop 1

Typically caused by loops being too far apart or very small vehicles

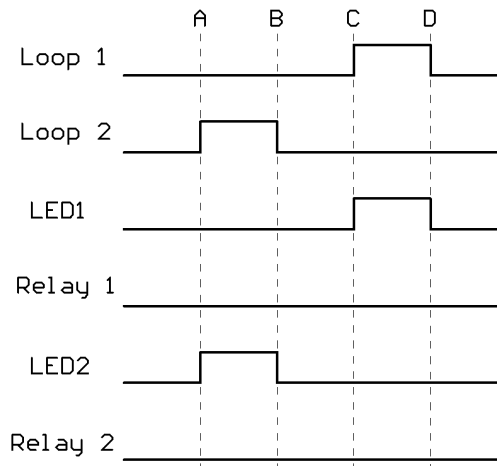

Case 4: (AB LOGIC Presence Mode)

Reverse direction

- A - Vehicle Enters Loop2
- B - Vehicle Enters Loop1
- C - Vehicle Exits Loop 2
- D - Vehicle Exits Loop 1

This is the correct reverse operation for Presence AB Logic

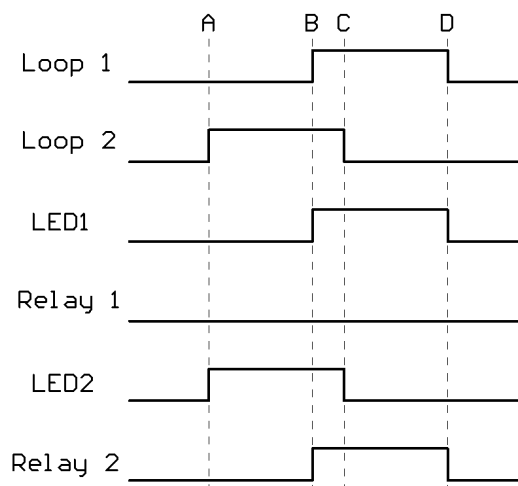

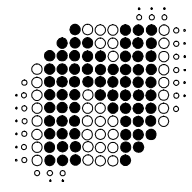

Case 5: (AB LOGIC Presence Mode)

Forward direction

- A - Vehicle Enters Loop1
- B - Vehicle Enters Loop2
- C - Vehicle Starts to reverse
- D - Vehicle Exits Loop 2
- E - Vehicle Exits Loop 1

This case should not happen but it does occasionally

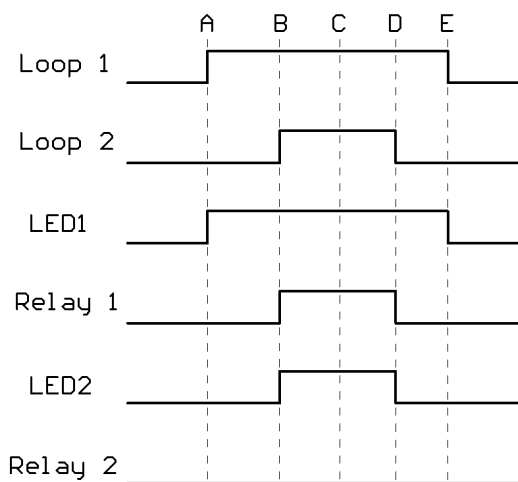

Case 6: (AB LOGIC Presence Mode)

Reverse direction

- A - Vehicle Enters Loop2
- B - Vehicle Enters Loop1
- C - Vehicle Starts to reverse
- D - Vehicle Exits Loop 1
- E - Vehicle Exits Loop 2

This case should not happen but it does occasionally

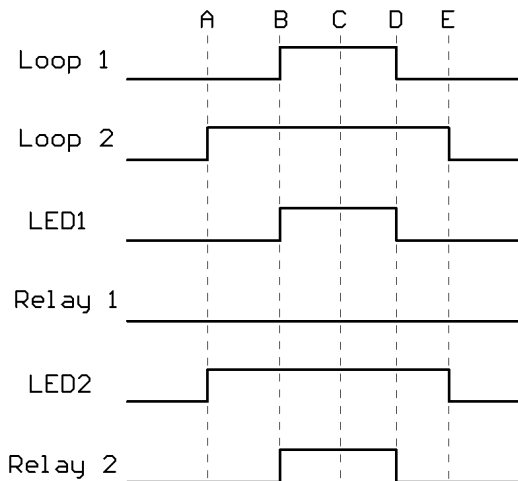

4.3.4 AB Logic Pulse Mode (Counting Logic)

Internal link LK1 shorted from Pin 2 to Pin 3. In this mode switches 9 & 10 are ignored.

AB LOGIC Pulse Mode is a direction logic mode, and is capable of determining direction of travel of a vehicle. Two loops are laid in the direction of travel to provide the input for this mode.

This mode is used to activate equipment requiring vehicle direction inputs such as automatic fee collection equipment, vehicle counters, or warning devices in one-way systems.

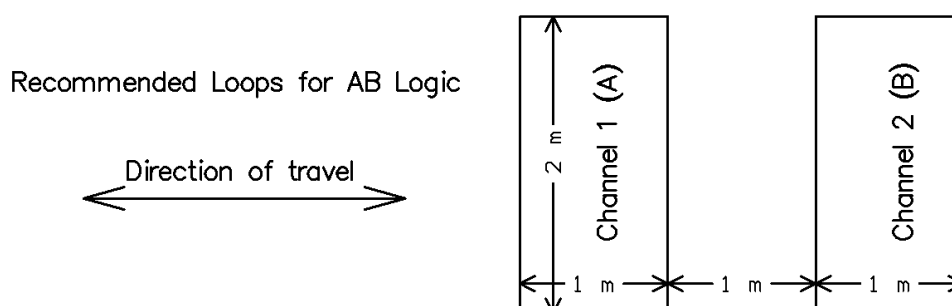

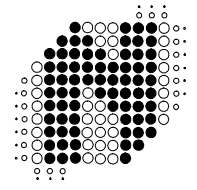

If a vehicle enters Channel 1 Loop and then proceeds to Channel 2 Loop, a 150 ms pulse will be issued on Channel 1 relay output as the vehicle leaves Channel 1 Loop.

If a vehicle now enters Channel 2 Loop and then proceeds to Channel 1 Loop, a 150 ms pulse will be issued on Channel 2 relay output as the vehicle leaves Channel 2 Loop.

Progress of a vehicle over the loops

Case 1: (AB LOGIC Pulse Mode)

Forward direction

- A - Vehicle Enters Loop1
- B - Vehicle Exits Loop 1,
- C - Vehicle Enters Loop2,
- D - Vehicle Exits Loop 2,

Typically caused by loops being too far apart or very small vehicles

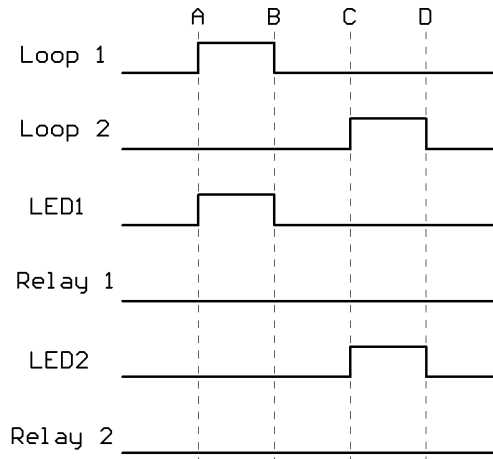

Case 2: (AB LOGIC Pulse Mode)

Forward direction

- A - Vehicle Enters Loop1
- B - Vehicle Enters Loop2
- C - Vehicle Exits Loop 1
- D - Vehicle Exits Loop 2

This is the correct forward operation for Pulse AB Logic

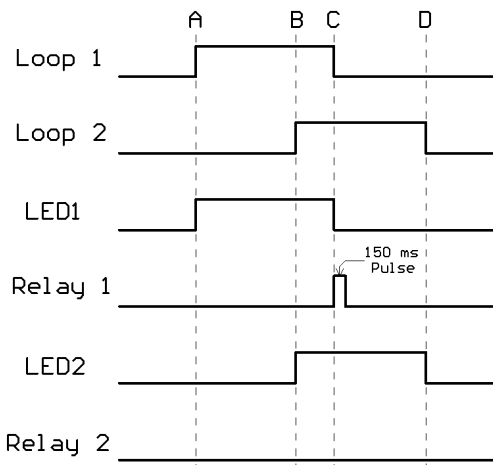

Case 3: (AB LOGIC Pulse Mode)

Reverse direction

- A - Vehicle Enters Loop2
- B - Vehicle Exits Loop 2
- C - Vehicle Enters Loop1
- D - Vehicle Exits Loop 1

Typically caused by loops being too far apart or very small vehicles

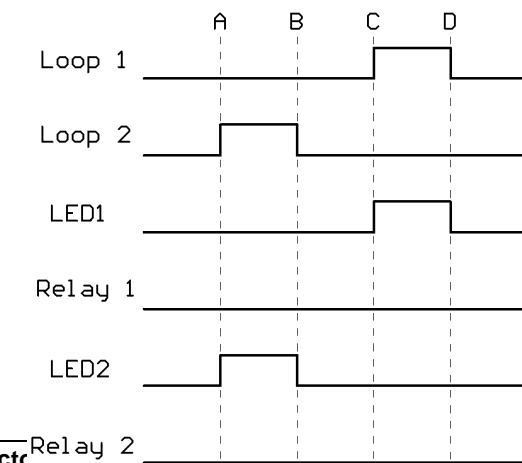

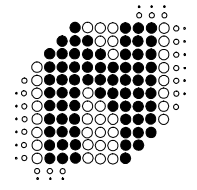

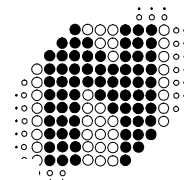

Case 4: (AB LOGIC Pulse Mode)

Reverse direction

- A - Vehicle Enters Loop2
- B - Vehicle Enters Loop1
- C - Vehicle Exits Loop 2
- D - Vehicle Exits Loop 1

This is the correct reverse operation for Pulse AB Logic

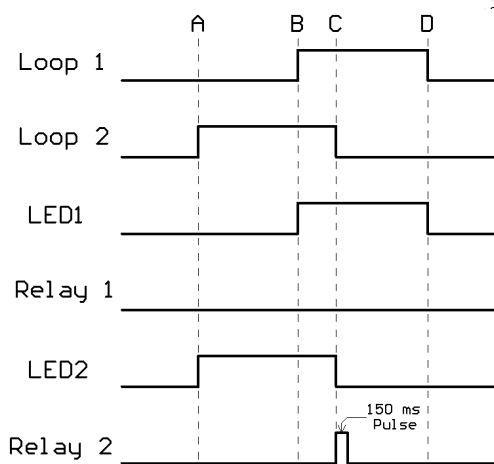

Case 5: (AB LOGIC Pulse Mode)

Forward direction

- A - Vehicle Enters Loop1
- B - Vehicle Enters Loop2
- C - Vehicle Starts to reverse
- D - Vehicle Exits Loop 2
- E - Vehicle Exits Loop 1

Forward direction. This case should not happen but it does occasionally

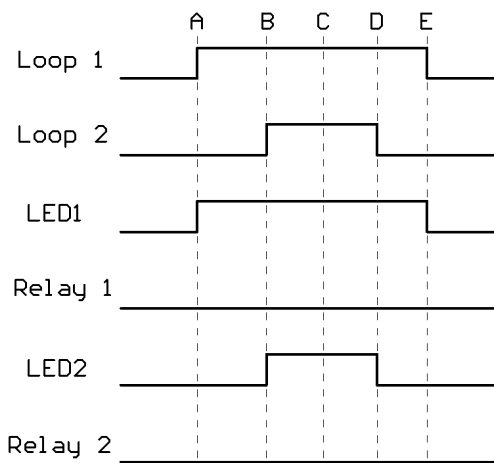

Case 6: (AB LOGIC Pulse Mode)

Reverse direction

- A - Vehicle Enters Loop2
- B - Vehicle Enters Loop1
- C - Vehicle Starts to reverse
- D - Vehicle Exits Loop 1
- E - Vehicle Exits Loop 2

Reverse direction. This case should not happen but it does occasionally

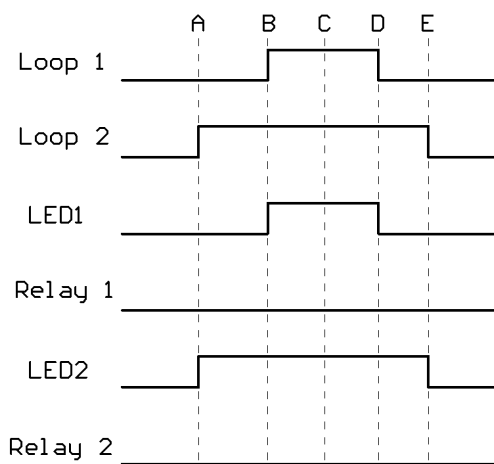

4.4 Response Times

The response time of the detector is the time taken from when a vehicle moves over the loop to when the detector gives an output on that channel.

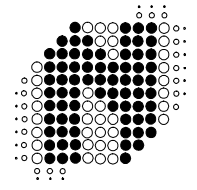

The response times of the PD230 Enhanced Detectors has been adjusted to prevent false operation in electrically noisy environments, but retains adequate response to vehicles in parking and vehicle access control applications.

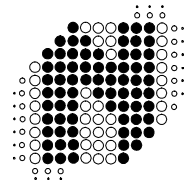

5. INSTALLATION GUIDE

Optimum functioning of the detector module is largely dependent on factors associated with the inductive sensor loop connected to it. These factors include choice of material, loop configuration and correct installation practice. A successful inductive loop vehicle detection system can be achieved by bearing the following constraints in mind, and strictly following the installation instructions. The detector must be installed in a convenient weatherproof location as close as possible to the loop.

5.1 Product Safety Requirements

- **i) WARNING:** The unit must be EARTHED.
- **ii) WARNING:** Disconnect the power before working on the unit.
- **iii) WARNING:** On 120 Vac and 230 Vac models, a readily accessible disconnect device must be incorporated into the mains wiring (as per EN60950-1:2005 Section 1.7.2.2).
- **iv) WARNING:** All models the power supply to the unit **MUST** have short circuit protection and over current protection installed at the power supply source (As per EN 60950-1:2005 section 1.7..2.3) typically this will be a 5 Amp Magnetic Circuit Breaker for AC models and a fuse for DC models.
- **v) WARNING:** This product must be installed in an enclosure.
- **vi) WARNING:** No user serviceable parts inside.

ONLY SERVICE PERSONNEL MAY OPEN THE UNIT TO CHANGE INTERNAL SETTINGS

- **vii) WARNING:** Only use **CE** approved 11 pin relay bases such as Nortech Part No. CTR119090 or equivalent.

As an alternative to the 11 pin relay base, Nortech has a 11 pin wiring harness, Nortech Part No. 302FT0041, which can only be used in SELV voltage (less than 60 V dc or less than 42 V ac) applications.

5.2 Operational Constraints

5.2.1 Environmental Factors to Consider

Even though the PD230 Enhanced parking detectors are housed, the system integrator **MUST** ensure that the detector is installed in a housing/fire enclosure to protect it from the environment.

The PD230 Enhanced parking detectors are rated to operate at from – 40°C to +70°C but the rate of temperature change **MUST** not exceed 1°C per minute. This system integrator **MUST** ensure that the housing used complies with this rate of temperature change requirement.

For installation **Outdoors** refer to Appendix B

For additional information on **Environmental Factors** refer to the section “Environmental Influences to Design Parameters” in the “Loops and Loop Installations” Manual, Nortech Document No. MKT05.

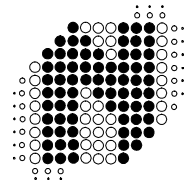

5.2.2 Crosstalk

When two or more loop configurations are in close proximity, the magnetic fields of one loop can overlap and disturb the field of another loop. This phenomenon, known as crosstalk, can cause false detects and detector lock-up.

Should the loops be connected to the same dual channel detector crosstalk will not occur, due to the fact that sequential polling of the loops takes place, resulting in only one loop being energised at a given time.

Crosstalk between adjacent loops operating from different detector modules can be eliminated by:

1. Careful choice of operating frequency. The closer together the two loops, the further apart the frequencies of operation must be.
2. Separation between adjacent loops. Where possible a minimum spacing of 2 metres between loops should be adhered to.
3. Careful screening of feeder cables if they are routed together with other electrical cables. The screen must be earthed at the detector end only.
4. Running feeder cables in their own slots, separated by at least 300 mm.

For additional information on **Crosstalk** refer to the section "Crosstalk Prevention" in the DU100 Diagnostic Unit User Manual Nortech Document No. 895UM0001

5.2.3 Reinforcing

The existence of reinforced steel below the road surface has the effect of reducing the inductance, and therefore the sensitivity, of the loop detection system. Hence, where reinforcing exists 2 turns should be added to the normal loop, as referred to in section 5.3.

The ideal minimum spacing between the loop and the cable and steel reinforcing is 150mm, although this is not always practically possible. The slot depth should be kept as shallow as possible, taking care that no part of the loop or the feeder remains exposed after the sealing compound has been applied.

5.3 Loop and Feeder Material Specification

Extensive studies have been undertaken over the years by various agencies around the world in order to ascertain the optimum loop installation materials.

As an insulated conductor is a prerequisite, PVC covered cable has been used for many years as a first choice, but tests have shown, in fact, that this is unsuitable for long term installations. The PVC tends to become porous with the result that adjacent loops become electrically coupled to one another, with resultant crosstalk implications. Instability and susceptibility to electrical interference can also result.

The insulation must withstand wear and abrasion from the shifting streets, moisture, and attack by solvents and oils, as well as withstand the heat of high temperature sealants.

Silicone insulated cable has emerged as one of the preferred insulation materials. Other insulation materials are rubber, thermoplastic, synthetic polymer and cross linked polyethylene.

Stranded loop wire is preferred over solid wire. Because of its mechanical characteristics, a stranded wire is more likely to survive bending and stretching than a solid.

A heavy gauge conductor is definitely desirable in order to maintain the loop Q-factor. The loop and feeder should preferably constitute a single length of insulated multi-stranded copper conductor, with

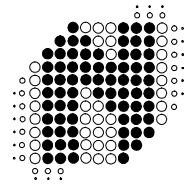

no joints and with the copper having a minimum cross section 1.5 mm^2 . The feeder is twisted to minimise the effect of electrical noise.

Joints in the loop or feeder are not recommended. Where this is not possible, joints are to be soldered and terminated in a waterproof junction box. This is extremely important for reliable detector performance. Other forms of joins such as those available in kits, where the joint is properly sealed against moisture, are also permitted.

5.4 Sensing Loop Geometry

- NOTE:**
- 1) The circumference of the loop must not exceed 30 m.
 - 2) The area of the loop must not exceed 30 m^2 and must not be less than 1 m^2 .
 - 3) The loop must be constructed as detailed below.

Sensing loops should, unless site conditions prohibit, be rectangular in shape and should normally be installed with the longest sides at right angles to the direction of traffic movement. These sides should ideally be 1 metre apart.

Loops operating from the same detector module can share a common slot along one of the longer sides, if so required. This type of configuration could be applied in a direction logic application. The maximum separation permitted for this application is 1 metre, ensuring that a vehicle can straddle both loops simultaneously in the required direction of travel.

The only factor which governs maximum separation between loops in all other applications is the feeder length, with 100 metres being the maximum recommended length.

The length of the loop will be determined by the width of the roadway to be monitored. The loop should reach to within 300 mm of each edge of the roadway.

In general, loops having a circumference measurement in excess of 10 metres should be installed using two turns of wire, while loops of less than 10 metres in circumference should have three turns. Loops having a circumference measurement less than 6 metres should have four turns.

It is good practice at time of installation to construct adjacent loops with alternate three and four turn windings.

For additional Information on loop geometry refer to the following documents:

- "INDUCTIVE LOOP VEHICLE DETECTION" - Nortech Doc. No. MKT0001.
- "TRAFFIC DETECTION" - Nortech Doc. No. MKT0002.
- "PARKING APPLICATIONS MANUAL" - Nortech Doc. No. MKT0003.
- "LOOPS and LOOP INSTALLATION" – Nortech Doc. No. MKT05

5.5 Loop Installation

All permanent loop installations should be installed in the roadway by cutting slots with a masonry cutting disc or similar device. A 45° crosscut should be made across the loop corners to reduce the chance of damage that can be caused to the loop at right angle corners.

NOMINAL SLOT WIDTH: 4 mm
NOMINAL SLOT DEPTH: 30 mm to 50 mm

A slot must also be cut from the loop circumference at one corner of the loop to the roadway edge to accommodate the feeder.

A continuous loop and feeder is obtained by leaving a tail long enough to reach the detector before inserting the cable into the loop slot. Once the required number of turns of wire are wound into the slot around the loop circumference, the wire is routed again via the feeder slot to the roadway edge.

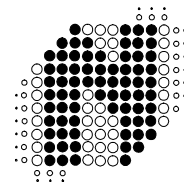

A similar length is allowed to reach the detector and these two free ends are twisted together to ensure they remain in close proximity to one another. (Minimum 20 turns per metre). Maximum recommended feeder length is 100 metres. It should be noted that the loop sensitivity decreases as the feeder length increases, so ideally the feeder cable should be kept as short as possible.

The loops are sealed using a “quick-set” black epoxy compound or hot bitumen mastic to blend with the roadway surface.

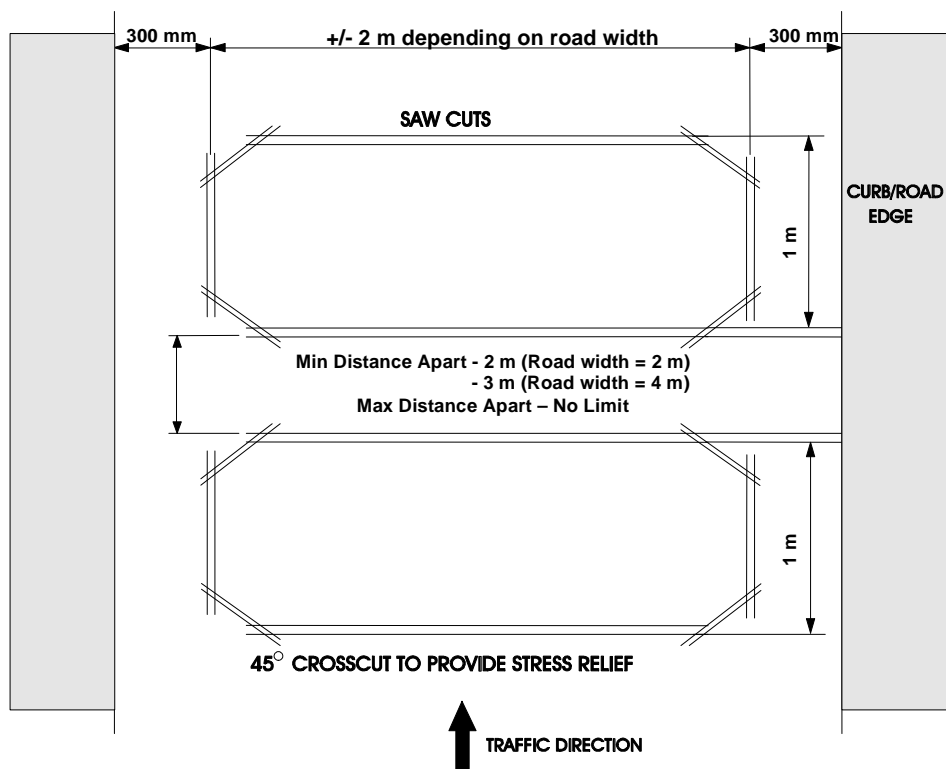

Figure 5.1 Adjacent loops connected to different detector modules

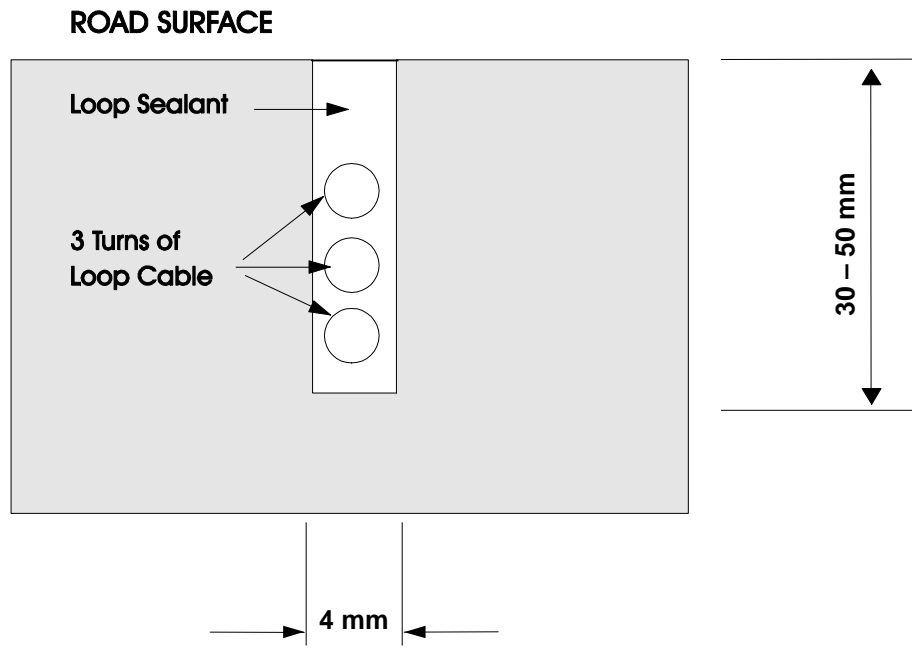
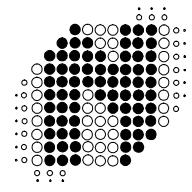
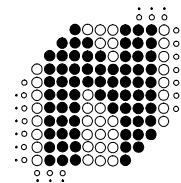

Figure 5.2 Slot details



6. CONFIGURATION

WARNING: 8. The connector PIN assignments vary from model to model.

Refer to the label on the side of the unit for connector PIN assignment.

NOTE 1: The tables below show the PIN assignments for Nortech's standard PD230 Enhanced detector models, on other models the pin assignments may change.

WARNING: 9. The wiring harness is only rated for SELV voltages (less than 60 V dc or less than 42 V ac).

If the relays are to switch higher voltages use CE LVD approved 11 pin sockets.

NOTE 2: All relay contact descriptions refer to the tuned and undetected state.

6.1 PD231 Enhanced Detector : English

11 – PIN CONNECTOR WIRING for: 302FT0014

302FT0041 WIRING HARNESS WIRE COLOUR	11 PIN Connector Pin No.	Function	
Red	1	Live	120 V AC \pm 10% 30 mA 60 Hz
Black	2	Neutral	
Blue	3	Channel 1 Loop	Twist this Pair
Blue	4	Channel 1 Loop	
Yellow	5	Channel 2 Loop	Twist this Pair
Yellow	6	Channel 2 Loop	
Grey	7	Channel 2 N/O Relay Contact	
Grey	8	Channel 2 Relay Common Contact	
Green/Yellow	9	Earth	
White	10	Channel 1 N/O Relay Contact	
White	11	Channel 1 Relay Common Contact	

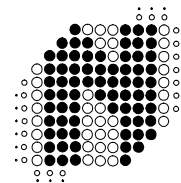

6.2 PD232 Enhanced Detector: English

11 – PIN CONNECTOR WIRING for: 302FT0026

302FT0041 WIRING HARNESS WIRE COLOUR	11 PIN Connector Pin No.	Function	
Red	1	Live	230 V AC \pm 10% 20 mA 50 Hz
Black	2	Neutral	
Blue	3	Channel 1 Loop	Twist this pair
Blue	4	Channel 1 Loop	
Yellow	5	Channel 2 Loop	Twist this pair
Yellow	6	Channel 2 Loop	
Grey	7	Channel 2 N/O Relay Contact	
Grey	8	Channel 2 Relay Common Contact	
Green/Yellow	9	Earth	
White	10	Channel 1 N/O Relay Contact	
White	11	Channel 1 Relay Common Contact	

6.3 PD234 Enhanced Detector: English

11 – PIN CONNECTOR WIRING for: 302FT0008

302FT0041 WIRING HARNESS WIRE COLOUR	Pin No.	Function	
Red	1	12 – 24V AC/DC \pm 10%	
Black	2	45 – 65 Hz 200 mA max	
Blue	3	Channel 1 Loop	Twist this pair
Blue	4	Channel 1 Loop	
Yellow	5	Channel 2 Loop	Twist this pair
Yellow	6	Channel 2 Loop	
Grey	7	Channel 2 N/O Relay Contact	
Grey	8	Channel 2 Relay Common Contact	
Green/Yellow	9	Earth	
White	10	Channel 1 N/O Relay Contact	
White	11	Channel 1 Relay Common Contact	

WARNING: 10. The wiring harness wire colour to PIN No. assignment only applies to the stated wiring harness Part No.

Other wiring harnesses will have different wire colour to PIN No. assignments.

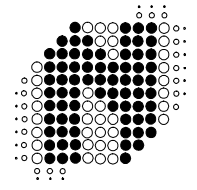

7. APPLICATIONS

The PD230 Enhanced dual channel detectors can be used in a variety of applications in the parking and door/gate environments.

- To arm card readers and ticket dispensers
- As a barrier/gate/door closing detector
- As a barrier/gate/door opening detector (Free exit)
- To generate pulses for vehicle counting
- As a logic unit to determine the direction of traffic flow

Some of the features that make the PD230 Enhanced detectors ideal for these purposes have been described in the preceding paragraphs.

For more details on parking applications refer to "Parking Applications Manual", Document No. MKT0003.

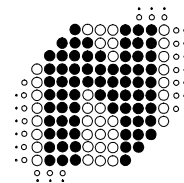

8. CUSTOMER FAULT ANALYSIS

8.1 Fault Finding

FAULT	CAUSED BY	REMEDY
Red LED does not glow on power up	If the indicator is off then there is a fault on the power connection to the unit.	Check power feed to the unit.
After the initial tune period the Ch1 and/or Ch2 indicator is green. Turning off for half second periods.	Unit cannot tune to the loop due to faulty loop or feeder connection. Loop may be too small or too large. Faulty detector unit.	Check loop installation and connections. Recut as per installation instructions. Replace unit.
After tuning, the loop output LED's flashes <u>intermittently</u> and the relay chatters	The loop is getting spurious detects due to: a) Crosstalk with adjacent detector. b) Faulty loop or feeder connection.	a) Change frequency setting. b) Check that the feeders are correctly connected and adequately twisted.

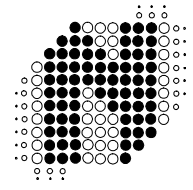

8.2 DU100 – Detector Diagnostic Unit

The DU100 Diagnostic unit is a hand-held test instrument that has been designed to operate with the PD230 Enhanced detector to provide installation/service personnel with positive verification of the correct operation of the vehicle detector and its installation.

The following parameters may be verified using this instrument:

1. Detector type and version
2. Loop status Display of loop frequency and magnitude of current change of loop inductance $\% \Delta L/L$.
3. Frequency Readout of the actual loop operating frequency and the magnitude of the frequency drift since the last re-tune.
4. Sensitivity Displays the Minimum and Maximum changes of Inductance $\% \Delta L/L$ that caused a detect since the last re-tune.
5. Status Displays the current status of the detector i.e. Undetect, Detect, Open circuit, Short circuit or Indeterminate.
6. Time The time in days and hours since the last re-tune and the reason for the last re-tune i.e. Reset: manual or power failure, Loop short circuit, Loop open circuit, Indeterminate or an Inductance change of greater than 15 % $\Delta L/L$ (typical).

This historical information is invaluable in providing information about intermittent faults.
7. Crosstalk Allows for the comparison of the operating frequencies of Detector loops in close proximity to each other. If the operating frequencies are too close the DU100 test will indicate a failure.

For further information refer to the Diagnostic Unit DU100 User Manual Document No. 895UM0001.

It is highly recommended that after installation of a detector (or if the loop has been changed in any way) that the DU100 Diagnostics Unit is used to verify the correct operation of the detector. A record of the readings should be kept so that if there is a problem in the future a comparison can be made to identify what has changed. The form in Appendix C could be used to record these readings.

8.2.1 Interpretation of the DU 100 readings

8.2.1.1 Frequency

For the PD230 Enhanced Detector the Minimum frequency is 24 kHz and the Maximum frequency is 78 kHz

If a 20 μH loop is connected directly (no feeder cable) to the Detector and the Frequency switches are set to "High Frequency" the typical frequency would be 78 kHz

If a 1000 μH loop is connected directly (no feeder cable) to the Detector and the Frequency switches are set to "Low Frequency" the typical frequency would be 24 kHz

If the Frequency reading from the DU100 is close to the Minimum Frequency the inductance of the LOOP is too large – you need to remove turns from the loop

If the Frequency reading from the DU100 is close to the Maximum Frequency the inductance of the LOOP is too low and you need to add turns to the loop

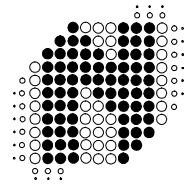

If the detector is operating close to either limit it is possible that either the frequency drift caused by environmental changes or the shift in frequency caused by a large $\Delta L/L$ detect will cause the frequency to go outside the limits and cause a retune.

8.2.1.2 Frequency drift

The PD230 Enhanced Detector can handle environmental conditions that can cause the frequency to drift up to at a rate of approximating 1% $\Delta L/L$ per minute.

If the Drift reading approaches this value the detector will have problems tracking the environmental change

If the drift is higher than say 0.5 % $\Delta L/L$ per minute this will indicate a possible fault with the loop or feeder cable. Possibly the wire insulation has deteriorated and moisture is causing a short to earth or that wires of the loop are no longer encapsulated and are moving.

For more information about Frequency drift refer to the “Theory of Application” section in Diagnostic Unit DU100 User Manual Document No. 895UM0001

8.2.1.3 Sensitivity

For a standard loop of 1.0 metres by 2.0 metres with 2 turns (circumference less than 10 meters) and a ten meter feeder cable the following table shows typical sensitivity values for different vehicle types

VEHICLE TYPE	% $\Delta L/L$
Metal Supermarket Trolley	
Bicycle	0.04
Motorbike	0.12
Articulated Truck	0.38
SUV (Four Wheel Drive)	0.40
5 Ton Tip Truck	0.45
Motor Car	> 1.00
Forklift	> 1.00

For more information about Sensitivity refer to the “Theory of Application” section in Diagnostic Unit DU100 User Manual Document No. 895UM0001

8.2.1.4 Time

This is a powerful tool in identifying problems with an installation. The time since the last retune of the detector will let you know when the event occurred and the reason will inform you of what caused the event

8.2.1.5 Crosstalk

For information about resolving crosstalk refer to the “Theory of Application” section in Diagnostic Unit DU100 User Manual Document No. 895UM0001

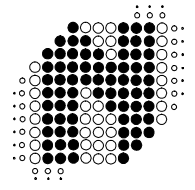

8.3 Functional Test

To test a detector, connect it to an inductive loop with a total inductance in the order of 300 microhenries. (This may be achieved in the workshop by winding (x) turns of wire on a non-metal former of diameter (y)).

x = 19 turns 0.25 mm wire
y = 238 mm (9.4 inches)

Bring a small metal object approximately the size of a matchbox close to the loop coil. The following will happen on detection:

The OUTPUT LED will light up.

The PRESENCE output relay will operate

The PULSE relay will operate momentarily (approximately 150 ms duration)

To check the sensitivity, presence time etc., use should be made of a calibrated tester, which comprises of a calibrated loop similar to the one described above with a moveable vane, which can be moved over the loop at pre-determined heights.

This device together with the DU100 hand-held test instrument will allow comprehensive analysis of the operating characteristics of the detector.

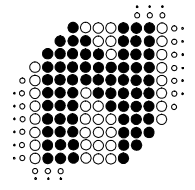

APPENDIX A - FCC ADVISORY STATEMENT

NOTE: This equipment has been tested and found to comply with the limits for a **Class B** digital device, pursuant to Part 15 of the FCC Rules. These limits are designed to provide reasonable protection against harmful interference in a residential installation.

Operation is subject to the following two conditions:

- 1 This device may not cause harmful interference, and
- 2 This device must accept any interference received, including interference that may cause undesired operation

This equipment generates, uses and can radiate radio frequency energy and, if not installed and used in accordance with the instructions, may cause harmful interference to radio communications.

However, there is no guarantee that interference will not occur in a particular installation. If this equipment does cause harmful interference to radio or television reception, which can be determined by turning the equipment off and on, the user is encouraged to try to correct the interference by one or more of the following measures:

- Reorient or relocate the receiving antenna.
- Increase the separation between the equipment and receiver.
- Connect the equipment into an outlet on a circuit different from that to which the receiver is connected.
- Consult the dealer or an experienced radio/TV technician for help.

The following booklets prepared by the Federal Communications Commission (FCC) may also prove helpful:

- How to Identify and Resolve Radio-TV Interference Problems (Stock No. 004-000-000345-4)
- Interface Handbook (Stock No. 004-000-004505-7)

These booklets may be purchased from the Superintendent of Documents, U.S. Government Printing Office, Washington, DC 20402.

WARNING: 10. Changes or modifications not expressly approved by the party responsible for compliance could void the user's authority to operate the equipment.

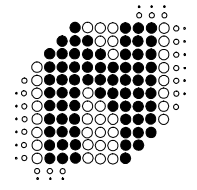

APPENDIX B – INSTALLATION OUTDOORS

Appendix B.1 IEC 60950-22:2005 – Outdoor cabinet

If the PD230 Enhanced Detector is to be installed outdoors it must be installed in a cabinet / housing that complies with the requirements of IEC 60950-22:2005 for a minimum of pollution degree 2.

Appendix B.2 IEC 60950-22:2005 - Northern Europe

To achieve outdoor operation down to -50 °C as required by IEC 60950-22:2005 for Northern Europe (Finland, Norway and Sweden) a heater with a thermostat must be included in the cabinet that houses the PD230 Enhanced Detector.

Appendix B.3 IEC 60950-1:2005 – Overvoltage Category

If the unit is likely to be exposed to transient overvoltage greater than IEC 60950-1 Overvoltage Category II additional protection must be provided external to the unit on the supply lines.

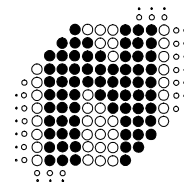

APPENDIX C - REQUEST FOR TECHNICAL SUPPORT FORM

For Technical support please fill in the form below and send it to your supplier. It is recommended that at installation you complete this form as a record of the Installation. If there is a problem later on you can identify what has changed.

For locating faults in “**Nortech Inductive Loop Vehicle Detector**” installations it is highly recommended that you use the DU100 DIAGNOSTICS UNIT. Please refer to the DU100 user manual Doc. No. 895UM0001 for details of how to operate the DU100.

Contact Details:- Your Name: _____

Your company: _____

Telephone No. _____ Mobile/Cellphone No. _____

FAX No. _____ Email Address _____

Postal address: _____

Product Model (i.e. PD234) _____ Product FT No. **302FT** _____

Product Serial Number: _____

Site Name: _____ Detector No. (at the site): _____

What are the settings of the switches on the front of the unit ON or OFF

- Switch 1 _____ (FREQ Frequency)
- Switch 2 _____ (FREQ Frequency)
- Switch 3 _____ (SENS Sensitivity Channel 2)
- Switch 4 _____ (SENS Sensitivity Channel 2)
- Switch 5 _____ (SENS Sensitivity Channel 1)
- Switch 6 _____ (SENS Sensitivity Channel 1)
- Switch 7 _____ (ASB Automatic Sensitivity Boost)
- Switch 8 _____ (PRES Presence Limited or Permanent)
- Switch 9 _____ (PULSE/PRES Pulse or Presence Channel 2)
- Switch 10 _____ (PULSE/PRES Pulse or Presence Channel 1)

What is the position of the internal link:(Pin 1 to 2 OR Pin 2 to 3 OR Open)? _____
(refer to section 3.3 above for functions of this link)

What application is this unit used in (short description) _____

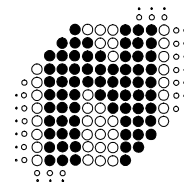

POWER SUPPLY DETAILS:

Nominal Voltage: _____ V Minimum Voltage: _____ V Maximum Voltage: _____ V

AC or DC ? _____ If AC then the Frequency _____ Hz

LOOP DETAILS

Channel 1

Channel 2

Size of loop: _____ m by _____ m

Size of loop: _____ m by _____ m

Shape of loop: _____

Shape of loop: _____

Number of Turns: _____

Number of Turns: _____

Size of wire used (mm² or AWG) _____

Size of wire used (mm² or AWG) _____

Type of wire insulation _____

Type of wire insulation _____

Thickness of insulation: _____ mm

Thickness of insulation: _____ mm

How far below the surface is the loop: _____ mm

How far below the surface is the loop: _____ mm

Are there any metal objects below the loops such as concrete reinforcing, water pipes etc if yes please give details:

Are there any power cables below these loops (Yes/No) _____ If yes please give details:

Are there any other loops in the area (Yes/No) _____ If so how many? _____ and

how close to these loops are they? _____ m

FEEDER CABLE DETAILS

Channel 1

Channel 2

Length of feeder cable _____ m

Length of feeder cable _____ m

Size of wire used (mm² or AWG) _____
(should be 1.5 mm² or larger)

Size of wire used (mm² or AWG) _____

Type of wire insulation _____

Type of wire insulation _____

Thickness of insulation: _____ mm

Thickness of insulation: _____ mm

Type of feeder cable used (screened, armoured, multicore, etc.)

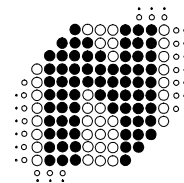

In the feeder cable how many twists per meter are there? _____ (should be more than 20 per metre)

Are there any other cables close to these feeder cables? (Yes/No) _____ If yes please give details:

FEEDER CABLE and LOOP DETAILS

Channel 1

Is the loop and feeder cable one continuous piece of wire or is there a joint between the loops and the feeder? (Yes/No) _____

Please give details: _____

Channel 2

Is the loop and feeder cable one continuous piece of wire or is there a joint between the loops and the feeder? (Yes/No) _____

With the detector disconnected, measure the following:-

Channel 1

AC voltage between the two wires of the feeder cable _____ V

AC voltage between one of the feeder cable wires and earth _____ V

DC resistance of Feeder plus Loop: _____ ohms

Inductance of Feeder plus Loop: _____ μ H

Frequency of measurement? _____ KHz

Loop and feeder resistance to earth (with detector unplugged) using a

500V Megger: _____ Mega Ohms
(should be greater than 10 Mega Ohms)

Channel 2

AC voltage between the two wires of the feeder cable _____ V

AC voltage between one of the feeder cable wires and earth _____ V

DC resistance of Feeder plus Loop: _____ ohms

Inductance of Feeder plus Loop: _____ μ H

Frequency of measurement? _____ KHz

Loop and feeder resistance to earth (with detector unplugged) using a

500V Megger: _____ Mega Ohms
(should be greater than 10 Mega Ohms)

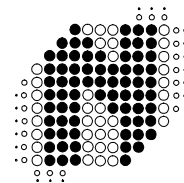

READINGS FROM DU100 DIAGNOSTICS UNIT

On arrival at site Time since last retune: _____ days _____ hours

Reason for Retune (Reset: manual or power failure, Short circuit, Open circuit, Indeterminate, Inductance change of greater than 15 % Δ L/L (typical):

Channel 1

Frequency _____ kHz

Loop Frequency Drift _____ %

Sensitivity Min: _____ % Δ L/L

Sensitivity Max: _____ % Δ L/L

Channel Status: _____

(Undetect, Detect, Open circuit, Short circuit or Indeterminate)

Channel 2

Frequency _____ kHz

Loop Frequency Drift _____ %

Sensitivity Min: _____ % Δ L/L

Sensitivity Max: _____ % Δ L/L

Channel Status: _____

(Undetect, Detect, Open circuit, Short circuit or Indeterminate)

Inductance Change for each vehicle type (Use the maximum sensitivity reading from the DU100 and reset the detector between each reading):

Vehicle Type	Channel 1 Inductance Change	Channel 2 Inductance Change
Bicycle	% Δ L/L	% Δ L/L
Motorbike	% Δ L/L	% Δ L/L
Car	% Δ L/L	% Δ L/L
SUV	% Δ L/L	% Δ L/L
Articulated truck	% Δ L/L	% Δ L/L
5 Ton Tip Truck	% Δ L/L	% Δ L/L
Forklift	% Δ L/L	% Δ L/L
Other type (Please specify)	% Δ L/L	% Δ L/L

Channel 1

Crosstalk (Pass / Fail): _____

(If fail actual frequencies of the two problem detector loops)

Frequency 1: _____ kHz

Frequency 2: _____ kHz

Channel 2

Crosstalk (Pass / Fail): _____

(If fail actual frequencies of the two problem detector loops)

Frequency 1: _____ kHz

Frequency 2: _____ kHz

Comments: _____

